

# Cake Display 1200mm - 4 Tier

| Food Displays



# Cake Display 1200mm - 4 Tier

| Food Displays

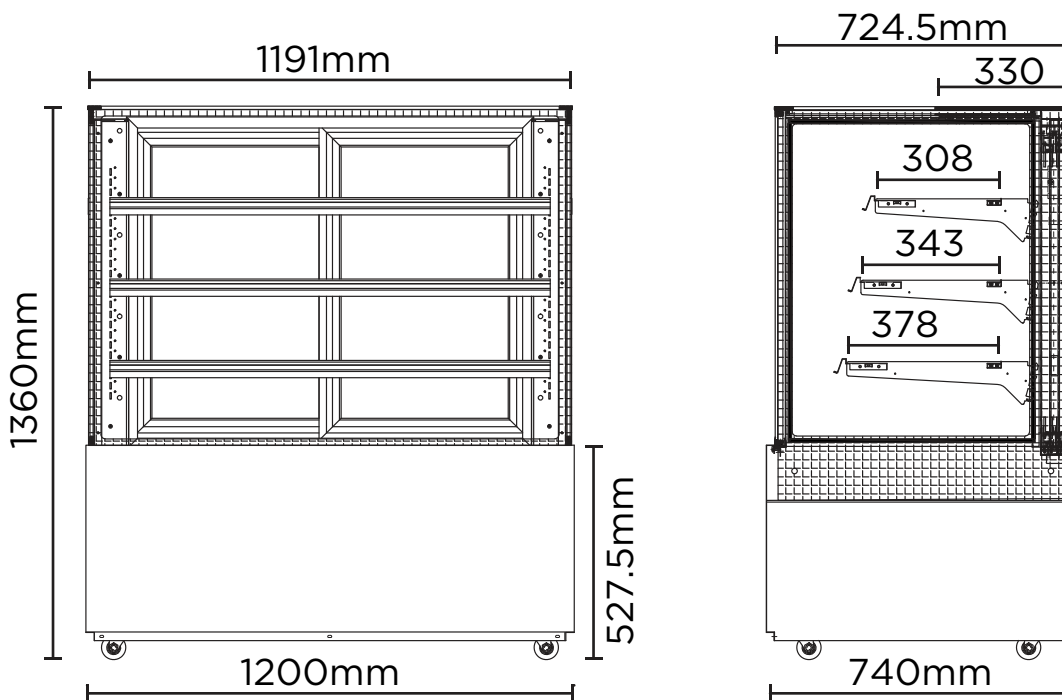

SPECIFICATIONS				DIMENSIONS	
Part Number	3736309-NR	Plug Location	Rear, Bottom Right	<b>External (mm)</b>	
Volume	542L	Internal Light	LED	<b>Width</b>	1200
Unit Weight	282kg	No. of Doors	2	<b>Depth</b>	740
Packaged Weight	292kg	Door Type	Glass	<b>Height</b>	1360
Adjustable Temp. Range	+1°C to +5°C	Door Glass Type	Double Glazed	<b>Internal (mm)</b>	
Max. Ambient Temp. Range	32°C	Door Style	Sliding	<b>Width</b>	1174
Climate Class	3M1	Self-Closing Door	No	<b>Depth</b>	647
Energy Consumption	14.87kWh/24h	No. of Shelves Incl. Base Per Door	4	<b>Height</b>	828
GEMS Star Rating	4 Stars	Shelves Type	Adjustable	<b>Internal (mm)</b>	
Refrigeration Capacity	1000W	Shelf Dimensions	1117(w) x 307(d), 1117(w) x 342(d), 1117(w) x 377(d) mm	<b>Width</b>	1300
Refrigerant	R290	Temp. Controller	Digital	<b>Depth</b>	850
Rated Current	4.2A	Castors	Yes	<b>Height</b>	1510
Electrical Voltage	220-240V	Warranty	5 Years Bromic Extra Care Warranty - Parts and Labour		
Frequency	50Hz				
Power Supply	Single Phase				
Power Plug	1 x 10A				