

INSTRUCTION MANUAL PIZZA PREP FRIDGES

3735801 & 3735802



CONTENTS

1. PREFIX	4
2. IMPORTANT NOTES & WARNINGS	5
3. PRODUCT OVERVIEW	6
4. INSTALLATION	7
5. OPERATION	10
6. PRODUCT LOADING AND STORAGE	11
7. MAINTENANCE	12
8. TROUBLESHOOTING	13
9. ENVIRONMENTAL & DISPOSAL NOTES	14
10. WARRANTY	15

1. PREFIX

This manual contains important information about the installation, operation, and maintenance of Bromic Pizza Prep Table. Please pay close attention to the important safety information shown throughout this instruction manual. Any safety information will be accompanied by the following safety alert symbols:

 DANGER,  WARNING,  IMPORTANT

- READ THIS MANUAL CAREFULLY before installing or servicing this product.
- Improper installation, operation, or maintenance can result in death, severe injury, or property damage.
- This appliance is intended for 230-240 Volt power supply.
- Installation MUST be carried out by a licensed and authorised technician in accordance with local electrical codes.

2. IMPORTANT NOTES AND WARNINGS

- Read all instructions before installing or using this appliance
- Retain this manual for future reference
- Use this appliance only as described in this manual. Any other use not recommended by the manufacturer may cause fire, electric shock or injury to persons.
- Improper installation, adjustment or alteration and failure to follow the warnings and instructions in this manual could result in severe personal injury, death or property damage
- The manufacturer is not responsible for any damage that could happen from improper use. The manufacturer emphasises that this appliance should be used in a responsible manner and that all procedures, warnings, and safety instructions contained in this booklet be followed strictly.
- Check the appliance for damage. Do not operate a damaged unit.
- Check for damage to the appliance regularly. If damage to the appliance is suspected, discontinue use immediately and contact the supplier or qualified person to repair.
- This appliance is not intended for use by persons (including children) with reduced physical, sensory or mental capabilities, or lack of experience and knowledge, unless they have been given supervision or instruction concerning use of the appliance by a person responsible of their safety.
- Keep packaging material out reach of children
- Children should be carefully supervised to ensure that they do not play with the appliance
- Do not attempt to alter the appliance in any manner.
- Please pay attention to the maximum load limit when filling the shelves.
- All work on electrical equipment must be carried out by a qualified and licenced technician only.
- Do not perform maintenance until the appliance has been turned off and power disconnected.
- Never detach any cover except where specifically instructed in this manual. Doing so might expose live electrical parts.
- Do not operate the appliance with panels, covers or guards removed.
- Keep the air intake and outlets free of obstructions.
- Do not use the appliance outdoors.
- If the supply cord becomes damaged, it must be replaced by an authorised service agent or similarly qualified person in order to avoid a hazard.
- If the appliance has not been used, or will not be used for a long period of time, disconnect power supply.
- Ensure the appliance has adequate ventilation.

3. PRODUCT OVERVIEW

		PP1700	PP2370
Part Number		3735801	3735802
External Dimension	Height, mm	1065	1065
	Width, mm	1702	2370
	Depth, mm	929	929
Capacity	Litres	572	873
Weight	kg	165	207
Air Circulation	Type	Forced	Forced
Climate Class	Rating	5M1 (40degC/40%RH)	5M1 (40degC/40%RH)
Temperature	Range	0°C to 5°C	0°C to 5°C
	Type	Digital	Digital
Exterior	Material	Stainless Steel	Stainless Steel
Interior	Material	Stainless Steel	Stainless Steel
Electrical	Voltage, V	240	240
	Frequency, Hz	50	50
	Current, A	3.4	4.0
Door	Solid/Glass	Solid	Solid
	Shape	Flat	Flat
	Self-Closing	Yes	Yes
	Door Lock	No	No
Shelves	Qty	4	6
	Type	Open rung shelf	Open rung shelf
	Width, mm	600	2 x 605, 4 x 660
	Depth, mm	643	643
	Adjustable	Yes	Yes
Refrigeration	Refrigerant	R134a	R404a
	Charge, g	340	360
Plug	Rating	10A	10A
Wheels	Type	Castors	Castors
	Brakes	Front only	Front only
	Size	4"	4"
	Quantity	4	6
Optional Accessories*	Work Bench	Tube Grill	Tube Grill

4. INSTALLATION

Locating the Cabinet

Ensure the following instructions are observed as this is vital for proper and trouble-free operation.

- Do not install the cabinet outdoors.
- Locate the appliance in a dry and well ventilated place.
- The unit must be positioned on a level surface.
- Do not install in the vicinity of heating radiators or other heat sources.
- Do not install the appliance where it is exposed to direct sunlight.
- Do not install the appliance where it is exposed to warm draughts or open doors.
- Keep the air intake and outlets free of obstructions.
- Adequate allowance should be made for door openings.

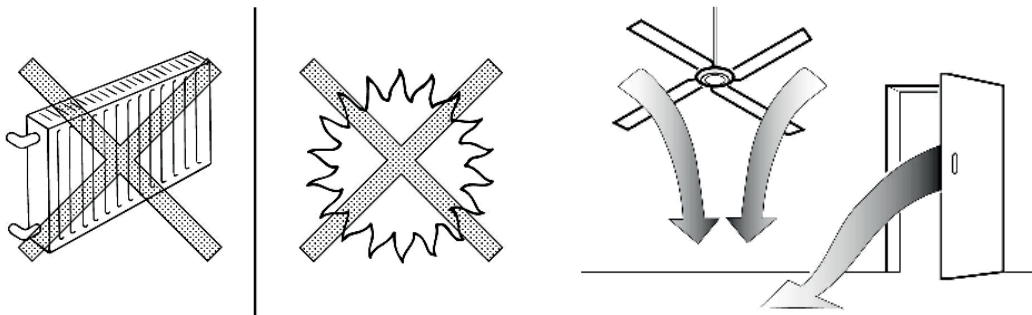

Ventilation

- Allow 150mm clearance between walls and the appliance.
- Ensure that the condenser fan is free to take in ambient air from the room.
- Adherence to minimum clearances is necessary

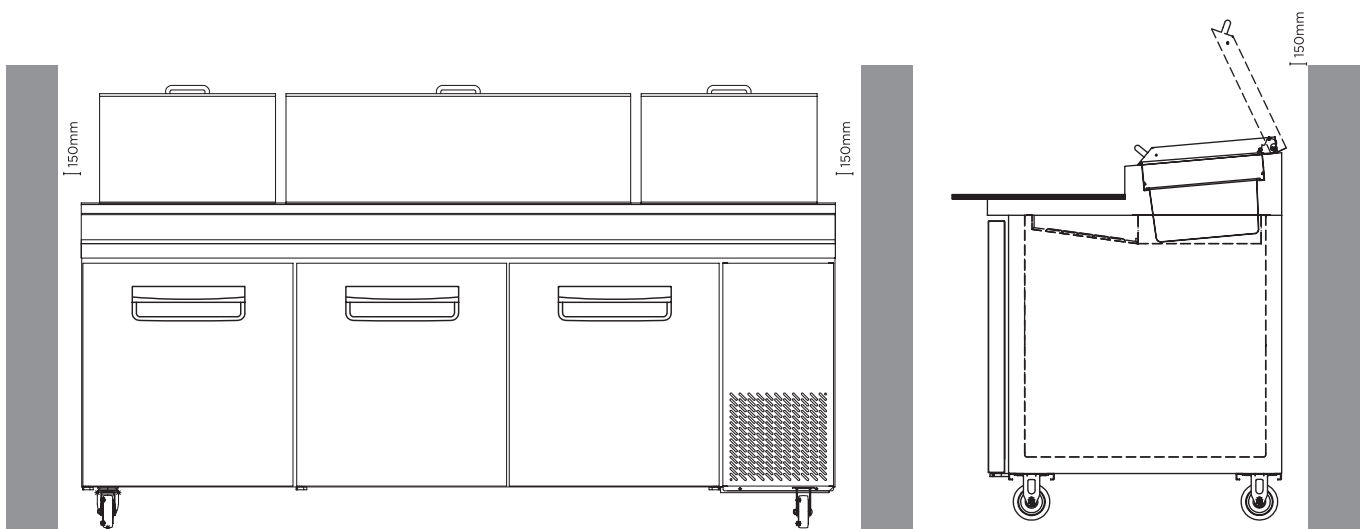

Power Supply

- The appliance must not be plugged into a multiple outlet power board.
- The appliance is supplied with a flexible power cord fitted with a 3-pin plug.
- The socket used must be properly earthed and fuse protected.
- See the rating label inside the cabinet for supply voltage, frequency and current draw.
- Power cable is rated 70°C. It is recommended that the cable should not come into contact with parts over 50°C.
- Do not turn off power before consulting the person responsible.
- Mark the power source clearly, so the refrigerator is not unplugged or turned off accidentally.

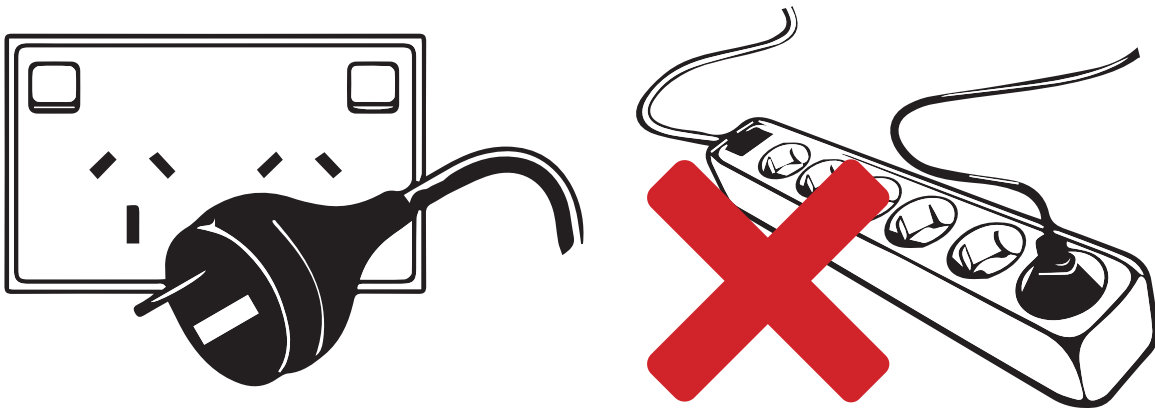

Before Operating

- If the appliance has been sharply tilted or transported in the horizontal position, it must be left to stand in the upright position and not plugged in for 1 hour.
- Remove all the packaging material before using the appliance.
- Start the appliance only if it has been installed as described.

Installing the tube grill

- Take the tube grill out of the box.
- Remove the cutting board mounting bracket to install the tube grill.
- Lift the tube grill tray and locate it on the bracket as shown below.

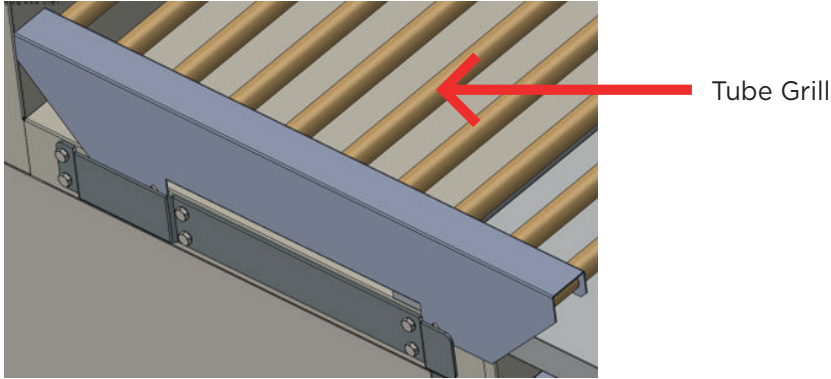

- The installation is complete, and the pizza prep table is ready for use.

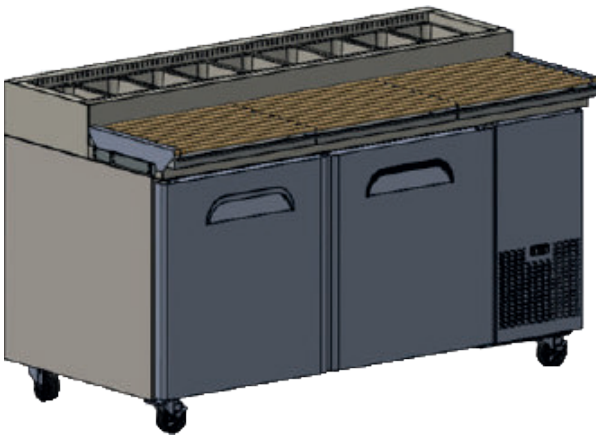

- Lift the tube grill assembly upwards to disassemble it from the pizza prep table.

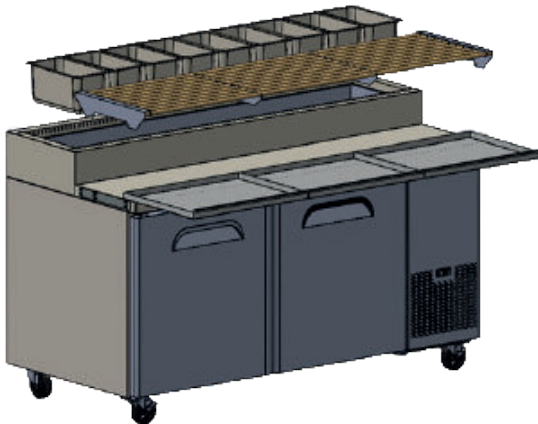

5. OPERATION

Start-up

- Connect the appliance to the mains power supply and check that the compressor, electronic controller, lighting and all fans are functioning correctly.
- The compressor and condenser fan should operate should operate 3 minutes after the unit has been connected to the power supply.
- The evaporator fan should operate after the unit has been plugged in.
- The electronic controller will display the current cabinet temperature after the unit has been connected to the power supply.
- The ❄️ LED indicates that refrigeration circuit is operating.
- During the start-up delay (3 minutes), the ❄️ LED is flashing
- The ❄️❄️ LED indicates that the refrigeration circuit is defrosting

Setting the temperature



- i. Press the **SET** button for more than 2 seconds.
- ii. The value of the set point will be displayed and the '°C' or '°F' LED starts blinking.
- iii. Press ▲ or ▼ arrow key within 10 seconds to adjust the set point.
- iv. Press the **SET** key again or wait 10 seconds.

6. PRODUCT LOADING AND STORAGE



IMPORTANT: Run the refrigerator for at least 2 hours before loading.



WARNING: Do not store explosive substances such as aerosol cans with a flammable propellant inside the appliance.

Start-up

- Clean the interior surface with a soft cloth and warm water before loading.
- Ensure there is free circulation of air between the products.
- Do not block the evaporator fan.
- Do not overstock the refrigerator.
- Keep refrigerator door openings to a minimum.
- Some products are sensitive to ultraviolet (UV) light, please see storage guidelines from the manufacturer before removing from packaging.
- Maximum recommended shelf load is 20kg.

NOTE: Bromic cannot be responsible for loss of stock or damage to stock.

Please refer to the 'National Vaccine Storage Guidelines: Strive for 5' for more information on vaccine storage and handling or contact your local state or territory health department.

(<http://www.health.gov.au/internet/immunise/publishing.nsf/content/IMM77-cnt>)

7. MAINTENANCE



WARNING: Disconnect the appliance from the power supply before performing any maintenance. Never unplug the appliance by pulling on the cord. Always grasp the plug firmly and pull straight out of the outlet.



WARNING: Exposure to significant water ingress will void warranty and cause potential safety issues. If the unit should be exposed to water, please contact the manufacturer immediately.

IMPORTANT: Warranty may be void if there is no evidence of preventative maintenance is performed on the appliance.

Cleaning the Cabinet

- Remove the products and transfer to a suitable location prior to cleaning the inside of the cabinet.
- Do not use any aggressive or abrasive cleaning agents.
- Never use a water hose or a high-pressure jet to clean.
- Do not use sharp or pointed objects for cleaning.
- Clean the inside and outside of the appliance with a clean damp cloth or with a neutral cleanser.
- Dry all surfaces with a dry cloth.

Condenser Coil



IMPORTANT: The condenser coil must be cleaned with a vacuum or brush once a month. The condenser coil must be cleaned regularly to maintain the performance and minimise power consumption. A poorly maintained condenser coil can lead to failure of the unit and higher cabinet temperatures.

8. TROUBLESHOOTING



IMPORTANT: Repairs on the unit must be carried out by an authorised and licenced person only. Contact the manufacturer or an approved service agent for any repairs needed.

Symptom	Possible Cause(s)	
Unit does not work	A. No power supply	A. Check power supply
Cabinet Temperature Too High	A. Ambient temperature too high B. Inadequate ventilation C. Wall clearances below minimum distance D. Dirty condenser coil E. Ice build-up on evaporator coil	A. Relocate unit B. Keep ventilation slots free C. Adjust to minimum clearance D. Clean E. Check gaskets and set temperature
Cabinet Temperature Too Low	A. Set temperature too low	A. Adjust set temperature
Drip tray overflowing	A. Extreme operating condition	A. Relocate unit
Odour inside cabinet	A. Cabinet dirty	A. Clean

9. ENVIRONMENTAL AND DISPOSAL NOTES

These refrigerated cabinets are designed to high standards of environmental protection and recycling convenience. Cyclopentane, an environmentally friendly foaming agent, has been used. Cyclopentane is distinguished by zero ozone depletion potential (ODP) and zero global warming potential (GWP). The refrigerant used and contained within a hermetically tight circuit is environmentally friendly and does not contain chlorine and zero ODP.

The device must be disposed of in accordance with applicable regulations. The WEEE regulations must be observed.

In the interest of preventing environmental nuisance and promoting re-use of the high quality materials employed, used commercial refrigeration equipment must be collected for expert disposal and recycling. Therefore, observe the following disposal regulations:

- The cabinet must not be discarded with regular waste.
- The refrigeration circuit must not be damaged.
- Before disposal, make it unserviceable by disconnecting the power plug and cutting off the power cable.
- Consult your local authorities or authorised dealers for details of collection and disposal facilities.
- Children are often unable to recognise the dangers associated with commercial refrigeration equipment. Proper supervision must be maintained and children must be prevented from playing with discarded refrigerated cabinets.
- The refrigerant used in this appliance is flammable. The refrigeration circuit must not be damaged.



10. WARRANTY







All Bromic products are manufactured to the highest quality standard and are supported by our Extra Care Service Warranty, including guarantees against any material or workmanship defects; guarantees that cannot be excluded under Australian Consumer Law.





Warranty Terms vary across the range. Please ensure you are familiar with the Terms and Conditions that apply to the purchase of your Bromic product by referring to the Warranty Policy included with your purchased product.

Alternatively, you can also download the Warranty Policy at www.bromicgroup.com/warranty-information

HOW TO PLACE A SERVICE REQUEST

- Please call 1300 276 642 to place a warranty service request and let the operator know whether you need Priority A or B service. More information can be found below.
- Ensure you have the serial number of your product ready before contacting us.
- The serial number of your product can be found on a compliance plate located on the inside right and at the rear of your cabinet.

P/N#3735161-NR				
Serial number:	Model:			
	UC0650SD-NR			
ST21113A01GH65T004	Digital Thermostat Ventilated			
Description	Power:			
CHILLER UC0650SD-NR	AC220-240V 50Hz 1Ph			
UPRIGHT 1DR 650L S/S	MADE IN CHINA			

BROMIC REFRIGERATION				
Serial no.:	ST21113A01GH65T004			
Climatic classification:	4	Insulation Blowing Gas	C5H10	
Bromic Model:	UC0650SD-NR	g	120	
Bromic Part no.:	3735161-NR	Hz	50	
Refrigerant type:	R290			
Rated Voltage:	AC220~240V	MADE IN CHINA		
Rated current:	3.0A			
Net Weight:	135Kg			
Rated Wattage:	305W			
Max Lamp Wattage:	1.5W			

Compliance Plate Example 1

SERVICE REQUEST PRIORITY



PRIORITY A SERVICE

When the unit is **NOT** performing its primary function such as cooling or heating, or presents an OH&S or food safety risk



PRIORITY B SERVICE

When the unit is performing its primary function, and presents no OH&S or food safety risk. i.e. lights, gaskets, locks, door adjustment



SERVICE CALL PLACED BEFORE MIDDAY

Priority A - Technician to attend site within 4 hours
Priority B - Technician to attend site within 8 business hours



SERVICE CALL PLACED AFTER MIDDAY

Priority A - Technician attends site before midday on the following business day
Priority B - Technician attends site before 4pm on the following business day

BROMIC REFRIGERATION

10 Phiney Place, Ingleburn (Sydney)
NSW 2565 Australia
T. 1300 276 642

For further product information
bromicrefrigeration.com.au