

## Island Freezer End Cabinet 805L - 1856mm

| Island Freezers



# Island Freezer End Cabinet 805L - 1856mm

| Island Freezers

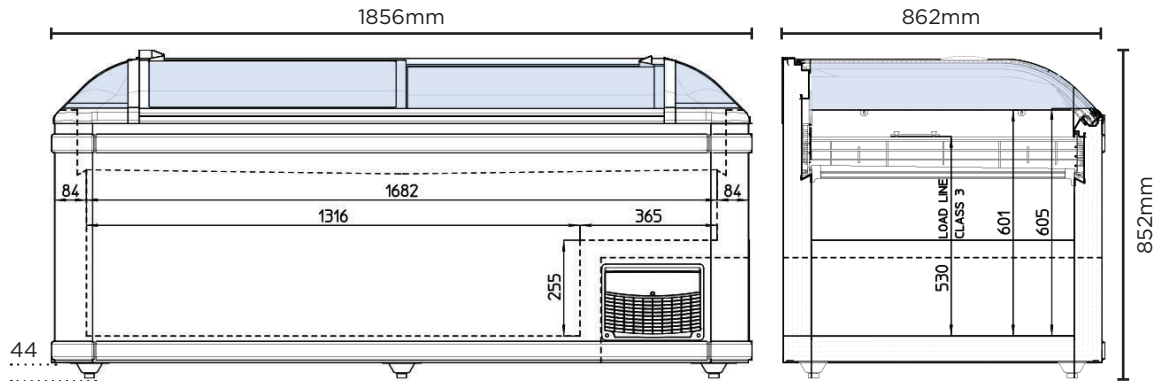

## Base & Basket Layout

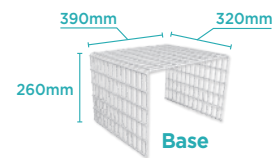
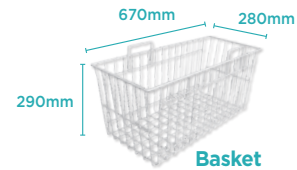
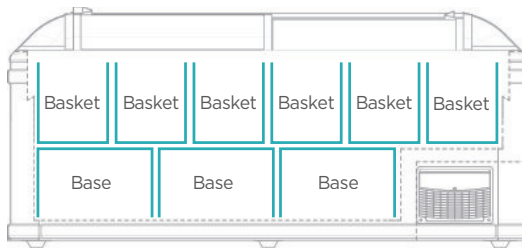

## SPECIFICATIONS

Model	IRENE ECO 185
Part Number	3735319
Unit Weight	161kg
Packaged Weight	171kg
Volume	805L
Total Display Area	1.7m <sup>3</sup>
Temperature Range	-25 to -18°C
Max. Ambient Temp.	25°C
Climate Class	3L1
Energy Consumption	8.692kWh/24h
GEMS Star Rating	4 Stars
Refrigeration Capacity	450W
Refrigerant	R290
Current	3.5A
Electrical Voltage	220-240V
Frequency	50Hz

Power Supply	Single Phase
Power Plug	2 x 10A
Plug Location	Underneath cabinet
Colour	White
Internal Light	Fluorescent
No. of Lids	2
Lid Type	Glass
Lid Shape	Curved
Lid Style	Sliding
No. of Baskets Incl.	6
Basket Dimensions	280(w) x 670(d) x 290(h) mm
No. of Bases Incl.	3
Base Dimensions	320(w) x 390(l) x 260(h) mm
Defrost System	Semi-Automatic
Temp. Controller	Digital
Wheels	Yes
Warranty	2 Years Parts & Labour Bromic Extra Care

## DIMENSIONS

	External (mm)
Width	1856
Depth	862
Height	852
	Internal (mm)
Width	1682
Depth	702
Height	753
	Packaged (mm)
Width	1985
Depth	980
Height	1010